

Preface

FR500H series is an enhanced type during all FRECON inverters group, special design for HVAC, air conditioner and water-supply industry, use for fan, pumps and other loads, support 2 modes water supply of fixed variable-frequency pump and cycle variable-frequency pumps, flexible control logic of add/reduce pumps, dormancy/awaken based on pressure, timing rotate control and other special functions.

When debugging the product, please refer to debugging guide in the user manual. Product maintenance please refers to FR500 user manual.

IMPORTANT NOTES

- ◆ To illustrate the details of the products, pictures in this manual based on products with outer casing or safety cover being removed. When using this product, please be sure to well install outer casing or covering by the rules, and operating in accordance with the manual contents.
- ◆ The illustrations this manual for illustration only and may vary with different products you have ordered.
- ◆ The company is committed to continuous improvement of products, product features will continue to upgrade, and the information provided is subject to change without notice.
- ◆ If you are using have questions; please contact our regional agents or our customer service center. Customer Service Tel 0755 -33067999.
- ◆ The company's other products please visit our website: <http://www.frecon.com.cn>

Contents

PREFACE..... - 1 -

CONTENTS..... - 2 -

CHAPTER 1 PRODUCT INFORMATION..... - 3 -

 1.1 NAMEPLATE INFORMATION - 3 -

 1.2 INFORMATION OF FR500H PRODUCT MODEL..... - 4 -

 1.3 TERMINAL CONFIGURATION - 4 -

 1.4 CONFIGURATION, MOUNTING DIMENSIONS AND WEIGHT..... - 9 -

CHAPTER 2 DEBUGGING GUIDE - 12 -

CHAPTER 3 LIST OF PARAMETERS - 14 -

 3.1 STANDARD FUNCTION PARAMETERS - 14 -

 3.2 H00 GROUP FUNCTION CODE DETAILED EXPLANATION - 26 -

CHAPTER 4 MAINTENANCE AND TROUBLESHOOTING - 34 -

Chapter 1 Product Information

1.1 Nameplate information

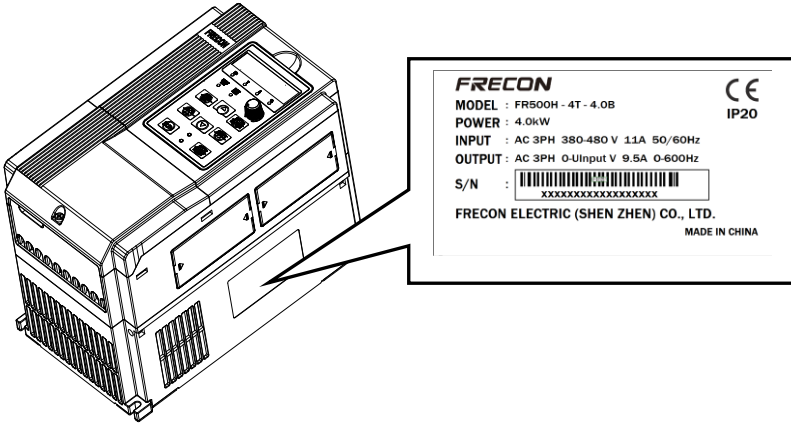

Fig.1-1 Nameplate information

Model Explanation

Model show on product nameplate contains information below

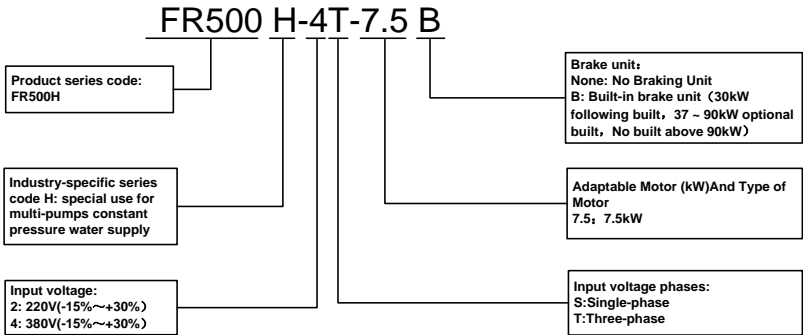

Figure 1-2 Product Model Number Naming Rule

1.2 Information of FR500H Product Model

Table 1-1FR500HProduct model and technical data

Model. No	Power capacity (KVA)	Rated Input current (A)	Rated output current (A)	Applicable motor	
				kW	HP
3-Phase: 380V, 50/60Hz Range: -15%~+30%					
FR500H-4T-1.5B	3	5.0	4.2	1.5	2
FR500H-4T-2.2B	4	5.8	5.5	2.2	3
FR500H-4T-4.0B	6	11	9.5	3.7、4	5
FR500H-4T-5.5B	8.9	14.6	13	5.5	7.5
FR500H-4T-7.5B	11	20.5	17	7.5	10
FR500H-4T-011B	17	26	25	11	15
FR500H-4T-015B	21	35	32	15	20
FR500H-4T-018B	24	38.5	37	18.5	25
FR500H-4T-022B	30	46.5	45	22	30
FR500H-4T-030B	40	62	60	30	40
FR500H-4T-037B	57	76	75	37	50
FR500H-4T-045	69	92	91	45	60
FR500H-4T-055	85	113	112	55	70
FR500H-4T-075	114	157	150	75	100
FR500H-4T-090	134	186	176	90	125
FR500H-4T-110	160	220	210	110	150
FR500H-4T-132	192	260	253	132	175
FR500H-4T-160	231	310	304	160	210
FR500H-4T-185	240	355	350	185	250
FR500H-4T-200	250	382	377	200	260
FR500H-4T-220	280	430	426	220	300
FR500H-4T-250	355	475	470	250	330
FR500H-4T-280	396	535	520	280	370
FR500H-4T-315	445	610	600	315	420
FR500H-4T-355	500	665	650	355	470
FR500H-4T-400	565	785	725	400	530
FR500H-4T-450	623	865	800	450	600

*Note: all the model is P type(light load type).

1.3 Terminal Configuration

1.3.1 Main Circuit Terminals

◆0.7~2.2KW Main Circuit Terminals

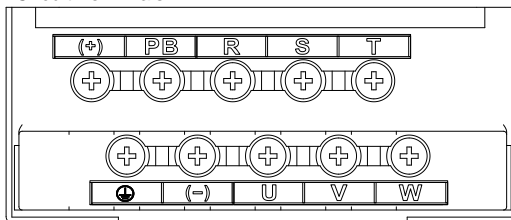

Fig.1-3 0.7~2.2kW Schematic of main circuit terminals

◆4~5.5KW Main Circuit Terminals

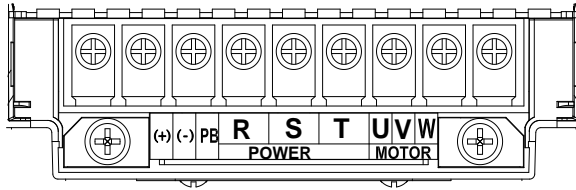

Fig.1-4 4~5.5kW Schematic of main circuit terminals

◆7.5~22KW Main Circuit Terminals

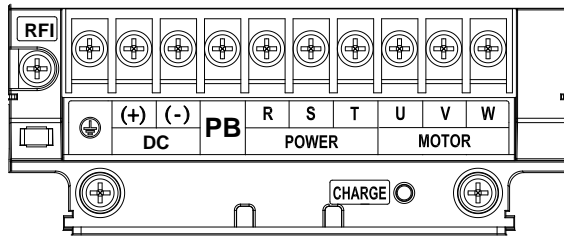

Fig.1-5 7.5~22kW Schematic of main circuit terminals

◆30~37KW Main Circuit Terminals

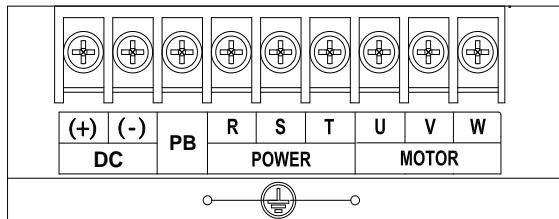

Fig.1-6 30~37kW Schematic of main circuit terminals

◆45~90KW Main Circuit Terminals:

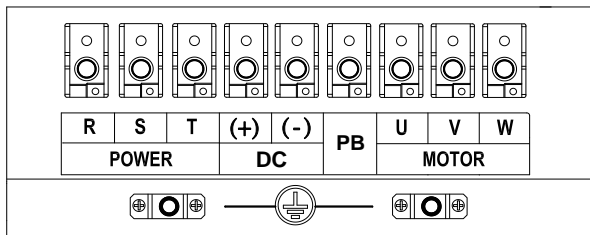

Fig.1-7 45~90kW Schematic of main circuit terminals

◆ 110~132KW , 250~280KW ,315~450KW Main Circuit Terminals:

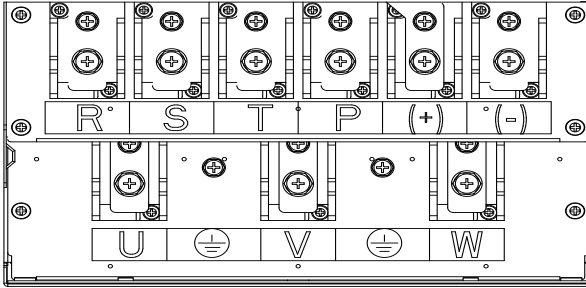

Fig.1-8 110~132KW , 250~280KW ,315~355KW Main Circuit Terminals

◆ 160~220KW Main Circuit Terminals:

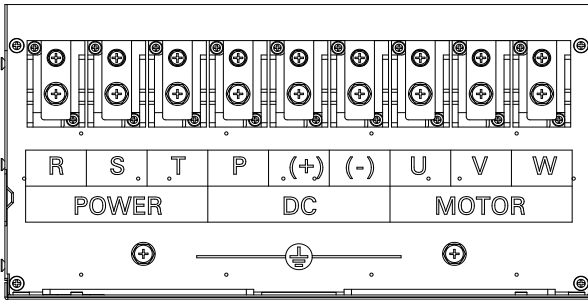

Fig.1-9 160~220KW Main Circuit Terminals

Table 1-2 main circuit terminal functions

Terminal Main marks	Designation and function of terminals.
R, S, T	AC power input terminals for connecting to 3-phase AC380V power supply.
U, V, W	AC output terminals of inverter for connecting to 3-phase induction motor.
(+), (-)	Positive and negative terminals of internal DC bus.
PB	Positive and negative terminals of internal DC bus. Connecting terminals of braking resistor. One end connected to + and the other to PB.
⊕	Grounding terminal.

1.3.2 Control circuit terminals

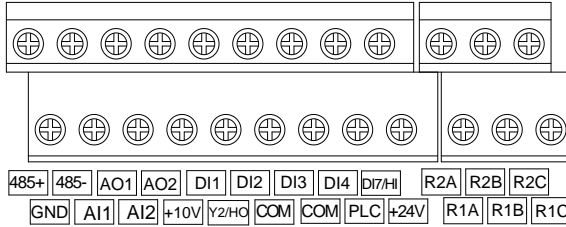

Fig.1-10 control circuit terminals (0.7~2.2kW)

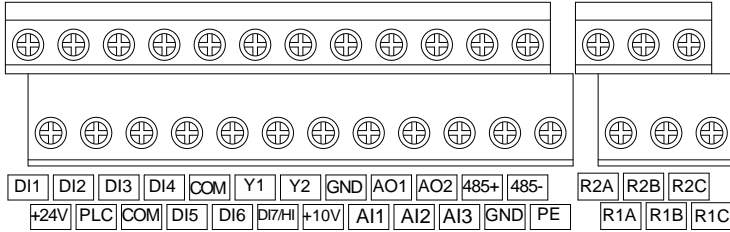



Fig. 1-11 control circuit terminals schematic(>2.2kW)

Table 1-3 FR500H Description of control circuit terminals

Type	Terminal	Name	Function Description
Power supply	+10V-GND	External +10 V power supply	Provide +10 V power supply to external unit. Generally, it provides power supply to external potentiometer with resistance range of 1~5 k Ω . Maximum output current: 10 mA
	+24V-COM	External +24V power supply Applying to Overvoltage Category II circuit	Provide +24 V power supply to external unit. Generally, it provides power supply to DI/Do terminals and external sensors. Maximum output current: 200 mA
	PLC	Input terminal of external power supply	Connect to +24 V by default. When DI1-DI7 need to be driven by external signal, PLC needs to be connected to external power supply and be disconnected from +24 V.
Analog input	AI1-GND	Analog input 1	Input voltage range: DC 0~10V/0~20mA, decided by toggle switches AI1、AI2 on the control board Impedance: 250 k Ω (voltage input), 250 Ω (current input)
	AI2-GND	Analog input 2	
	AI3-GND	Analog input 3	Input Voltage Range: DC -10~+10V Input impedance: 250k Ω
Switch input	DI1- COM	Switch input terminals 1	Maximum input frequency: 200Hz Impedance: 2.4k Ω Voltage range for level input: 9V~30V
	DI2- COM	Switch input terminals 2	
	DI3- COM	Switch input terminals 3	
	DI4- COM	Switch input	

FR500H Special Purpose Inverters for Multi-pumps Constant Pressure Water Supply

		terminals 4	
	DI5- COM	Switch input terminals 5	
	DI6- COM	Switch input terminals 6	
	DI7/HI-COM	Switch input terminals 7 OR High-speed pulse input	
Analog output	AO1-GND	Analog output terminal 1	Output voltage range: DC 0~10V/0~20mA, decided by toggle switches AO1、AO2 on the control board Impedance requirements≥10kΩ
	AO2-GND	Analog output terminal 2	
Switch output	Y1-COM	Open collector output 1	Voltage range: 0~24V Current range: 0~50mA
	Y2/HO-COM	Open collector output 2 OR High-speed pulse output	Besides features of Y1, it can be used for High-speed pulse output channels. The maximum output frequency: 100kHz
Relay output	R1A-R1C	Normally open terminal	Contact driving capacity: AC250V, 3A, COSØ=0.4. DC 30V, 1A
	R1B-R1C	Normally closed terminal	
	R2A-R2C	Normally open terminal	
	R2B-R2C	Normally closed terminal	
485 Communication	485+-485-	485 Communication Terminals	Rate: 4800/9600/19200/38400/57600/ 115200bps Termination resistor is set by the toggle switch on the control panel RS485
	GND	485 Communication shielded ground	
Shield	PE	Shield Ground	Ground terminal for shield
Auxiliary Interface		External operation panel interface	Use standard network cable Maximum cable distance: 50m
	UP/DOWNLOAD	Parameter copy interface	

1.4 Configuration, Mounting Dimensions and Weight

◆0.7~2.2KW Dimensions and wall mounting dimensions(scheme One):

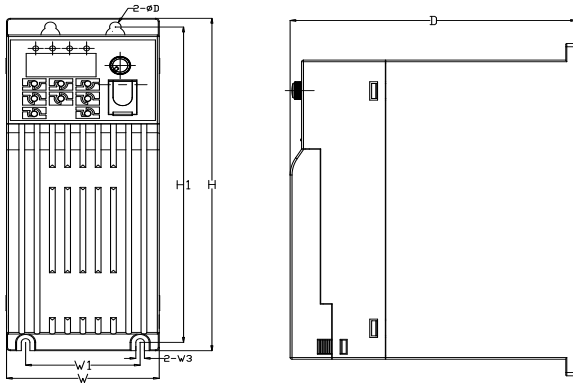

Fig 1-11 0.7~2.2kW Wall installation diagram(scheme One)

◆0.7~4.0KW Dimensions and wall mounting dimensions (scheme Two)

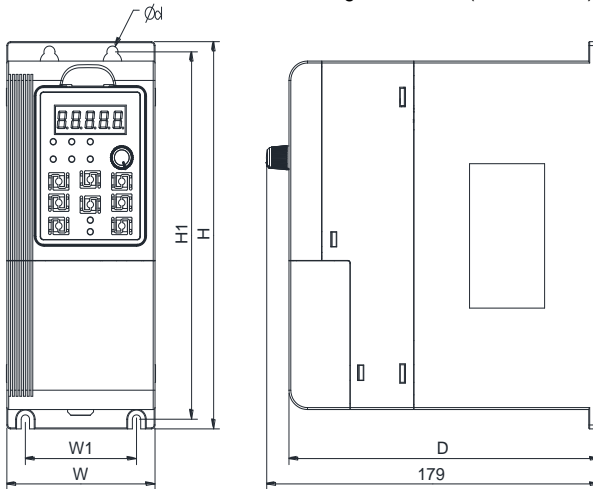

Fig 1-11(b) 0.7~4.0kW Wall installation diagram (scheme Two)

◆ 4~22KW Dimensions and wall mounting dimensions:

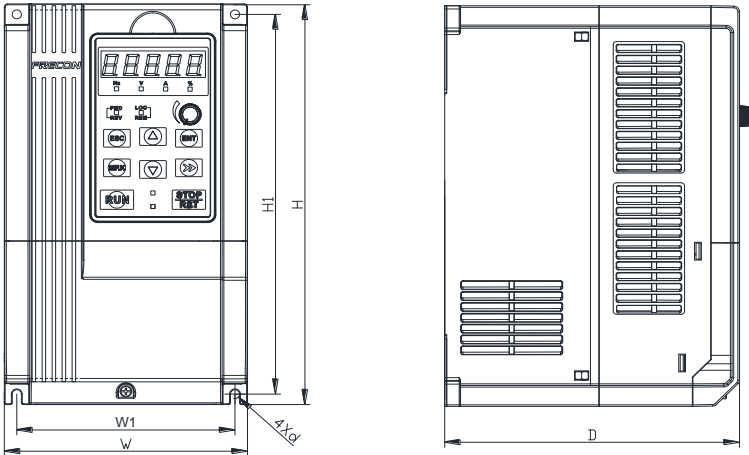

Fig 1-12 4~22kW Wall installation diagram

◆ 30~450kW Dimensions and wall mounting dimensions:

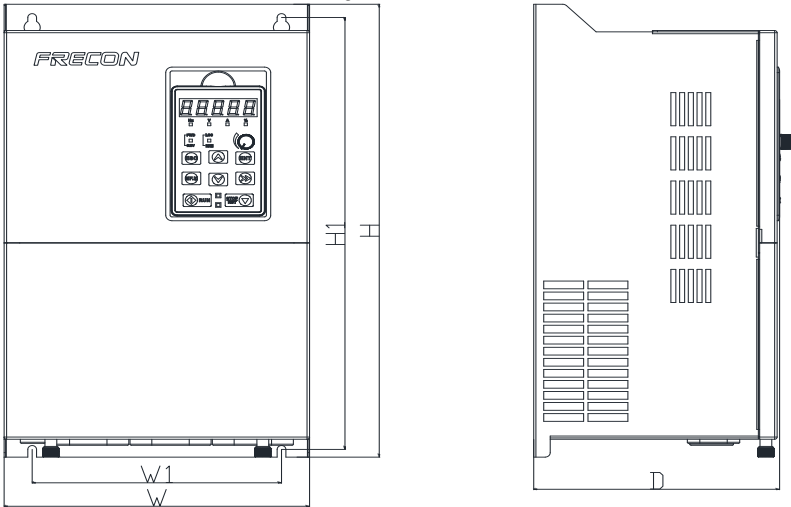

Fig 1-13 30~450KW Wall installation diagram

Table 1-4 Configuration, mounting dimensions and weight

Model NO.	External and installation dimensions (mm)						Weight (Kg)
	W	W1	H	H1	D	Mounting Hole Diameter	
3-Phase:380V, 50/60Hz Range:-15%~+30%							
FR500H-4T-1.5B	80	60	200	190	167	6	1.34 (1.25)
FR500H-4T-2.2B	(80)	(60)	(200)	(190)	(150)		
FR500H-4T-4.0B	116. 6	106.6	186.6	176.6	175	4.5	2.5
FR500H-4T-5.5B							
FR500H-4T-7.5B							
FR500H-4T-011B	146	131	249	236	177	5.5	3.9
FR500H-4T-015B	198	183	300	287	185	5.5	6.2
FR500H-4T-018B							
FR500H-4T-022B							
FR500H-4T-030B							
FR500H-4T-037B	245	200	410	391	200	7	11.8
FR500H-4T-045	300 (275)	200 (200)	485 (470)	466 (451)	226 (215)	7	15
FR500H-4T-055							
FR500H-4T-075							
FR500H-4T-090	310	200	620	601	280 (262)	9.5	26
FR500H-4T-110							
FR500H-4T-132	310 (400)	200 (300)	650 (750)	620 (724)	350 (300)	11.5	45
FR500H-4T-160							
FR500H-4T-185	400	300	750	724	300	11.5	68
FR500H-4T-200	500	300	855	822	320	12	112
FR500H-4T-220							
FR500H-4T-250							
FR500H-4T-280	540	340	924.5	896	380	12	120
FR500H-4T-315							
FR500H-4T-355	620	400	996	963	390	12	133
FR500H-4T-400							
FR500H-4T-450	700	500	1025. 5	988.5	390	14	195

*Note:

1. The data in parentheses in the above table is the size of scheme one

Chapter 2 Debugging Guide

FR500H series special purpose inverter for multi-pumps constant pressure water supply specially developed for constant pressure water supply industry, featured with 2 modes below:
 Mode 1: fixed variable frequency control mode wirings:

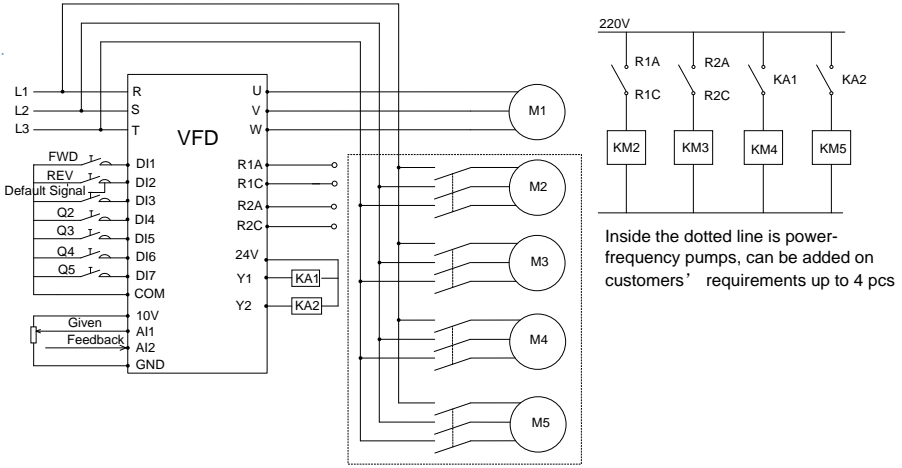

Fig. 2-1 Fixed Pumps Mode Wirings

Mode 2: two variable frequency pumps cycle control mode wirings:

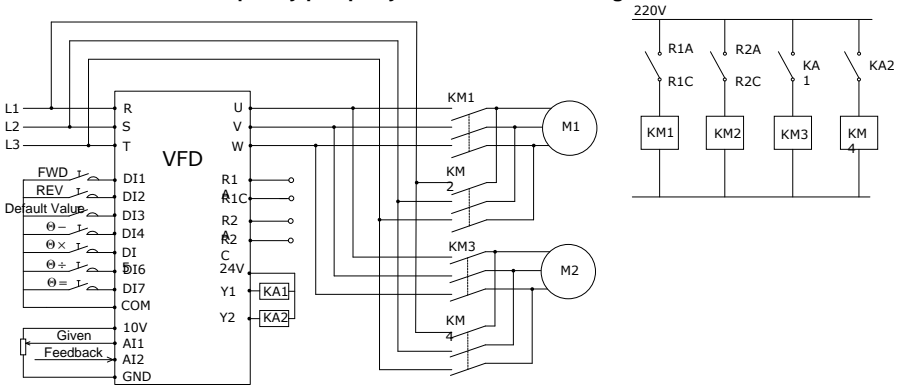
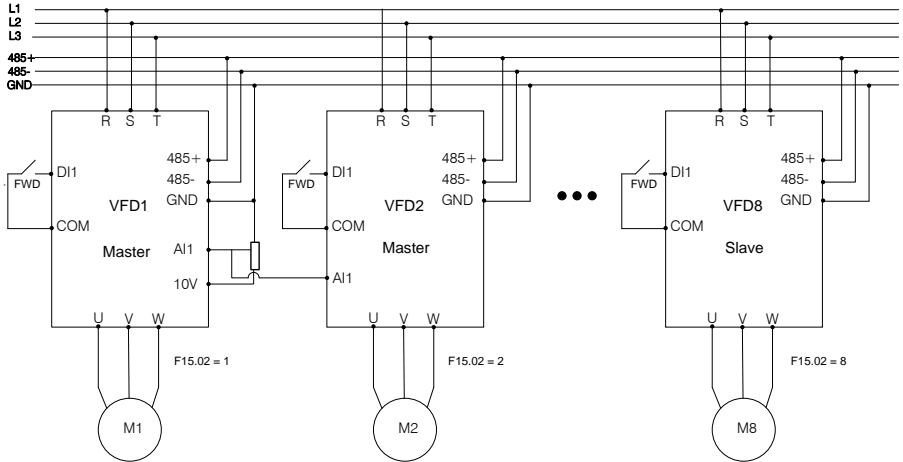

Fig. 2-2 two variable frequency cycle mode wirings

Mode 3: Multi follower mode**Mode 4: Multi master mode****Fig. 2-3 Multi Mode wirings**

1. Up to 8 drives supported.
2. All the drives should set the same mode(H00.01)
- 3.All the drives in the system should set H00.29=1(enable multi mode)
4. Support multi masters, and for all the masters, AI1 terminals should be connected. Set H00.31 to determine if the drive can be used as master or not.

Chapter 3 List of Parameters

3.1 Standard Function Parameters

Table 3-1 Standard Function Parameters

Param.	Parameter Name	Instructions	Default	Attr
Group F00: System Parameters				
F00.00	User Password	0~65535	0	x
F00.01	Display of Parameters	0: Display all parameters	0	x
		1: Only display F00.00, F00.01 and user-defined parameters F17.00~F17.29		
		2: Only display F00.00, F00.01, and the parameters different with factory default		
F00.03	G/P type display	0: G type (constant torque load)	1	x
		1: P type (variable torque load e.g. fan and pump)		
F00.04	Parameter Initialization	0: Invalid	0	x
		1: Restore all parameters to factory default (excluding motor parameters)		
		2: Clear fault record		
		3: Backup user parameters		
		4: Restore Back up parameters		
		5: Restore factory default (include motor parameters)		
6: Clear consumption				
Group F01: Frequency Command				
F01.01	Master Frequency Command Source	0: Master digital setting (F01.02)	6	x
		1: keypad potentiometer		
		2: Analog input AI1		
		3: Communication		
		4: Multi-reference		
		5: PLC		
		6: Process PID output		
		7: DI7/HI pulse input		
		8: Analog input AI2		
9: Analog input AI3				
F01.08	Maximum frequency	20.00~600.00Hz	50.00Hz	x
F01.09	Upper limit frequency	Fdown~Fmax	50.00Hz	x
F01.10	Lower limit frequency	0.00~Fu	0.00Hz	x
F01.11	Operation when command frequency lower than lower limit frequency	0: Run at lower limit frequency	0	x
		1: Run at 0 Hz would be activated after the time delay set by F01.12		
F01.12	Lower limit frequency running time	0.0~6000.0s	60.0s	x
Group F02: Start/Stop Control				
F02.00	Run command	0: Keypad control (LED off)	1	x
		1: Terminal control (LED on)		
		2: Communication control (LED blinking)		
F02.12	Stop mode	0: Ramp to stop	0	

FR500H Special Purpose Inverters for Multi-pumps Constant Pressure Water Supply

		1: Coast to stop		
F02.20	0Hz output selection	0:No-voltage output	0	x
		1:Voltage output		
Group F03: Accel/Decel Parameters				
F03.00	Accel time 1	0.0~6000.0s	15s	△
F03.01	Decel time 1	0.0~6000.0s	15s	△
Group F04 Digital Input				
F04.00	Function of terminal DI1	00: No function	1	x
F04.01	Function of terminal DI2	01: Running forward (FWD)	2	x
F04.02	Function of terminal DI3	02: Running reverse (REV)	9	x
F04.03	Function of terminal DI4	03: Three-wire running control	51	x
F04.04	Function of terminal DI5	04: JOG forward (FJOG)	52	x
F04.05	Function of terminal DI6	05: JOG reverse (RJOG)	53	x
F04.06	Function of terminal DI7	06: Coast to stop 07: Fault reset (RESET) 08: Running pause 09: External fault input 10: Terminal Up 11: Terminal DOWN 12: UP/DOWN (including \wedge/\vee key) adjustment clear 13: Multi-step frequency terminal 1 14: Multi-step frequency terminal 2 15: Multi-step frequency terminal 3 16: Multi-step frequency terminal 4 17: Accel/Decel time determinant 1 18: Accel/Decel time determinant 2 19: Accel/Decel disabled(ramp stop not inclusive) 20: Given frequency switching as the auxiliary frequency source 21: PLC status reset 22: Simple PLC paused 23: ID paused 24: PID adjustment direction 25: PID integration paused 26: PID parameter switch 27: Swing frequency pause (output the current frequency) 28: Swing frequency reset(output the central frequency) 29: Run command switched to keypad control 30: Run command switched to terminal control 31: Run command switched to communication control 32: Count input 33: Count clear 34: Length pulse input 35: Length clear 36: DC brake input command at stop 37:Speed/Torque control switch 38: Disable reverse 39: Disable forward 50: Special purpose inverter enable	54	x

FR500H Special Purpose Inverters for Multi-pumps Constant Pressure Water Supply

		51: No.1 pump status 52: No.2 pump status 53: No.3 pump status 54: No.4 pump status 55: No.5 pump status 56: Derag Function		
F04.13	Terminal DI1~DI5 positive/negative logic	DI5, DI4, DI3, DI2, DI1	00000	
		0: Positive logic(Terminals are on at 0V/off at 24V)		
		1: Negative Logic (Terminals are off at 0V/on at 24V)		
F04.14	Terminal DI6~AI3 positive/negative logic	AI3、AI2、AI1、DI7、DI6	00000	
		0: Positive logic		
		1: Negative Logic		
Group F05 Digital Output				
F05.00	Y1 output function	00: No output	33	x
F05.01	Y2 output function	01: Drive is running	34	x
F05.02	Relay 1 output function	02: Fault output	31	x
F05.03	Relay 2 output function	03: Frequency-level detection (FDT1)	32	x
		04: Frequency-level detection (FDT2)		
		05: Drive in 0Hz running 1 (no output at stop)		
		06: Drive in 0Hz running 2(output at stop)		
		07: Upper limit frequency attained		
		08: Lower limit frequency attained		
		09: Frequency attained		
		10: Inverter is ready to work		
		11: Drive (motor) overloaded alarm		
		12: Inverter overheat warning		
		13: Current running time attained		
		14: Accumulative power-on time attained		
		15: Consecutive running time attained		
		16: PLC cycle completed		
		17: Set count value attained		
		18: Designated count value attained		
		19: Length attained		
		20: Under-load warning		
		21: Brake output		
		22: DI1		
		23: DI2		
30: No.1 pump power-frequency control terminal				
31: No.2 pump power-frequency control terminal				
32: No.3 pump power-frequency control terminal				
33: No.4 pump power-frequency control terminal				
34: No.5 pump power-frequency control terminal				
35: No.1 pump variable-frequency control terminal				

FR500H Special Purpose Inverters for Multi-pumps Constant Pressure Water Supply

		36: No.2 pump variable-frequency control terminal		
F05.08	Enabled state of digital output	Unit: Y1	0000	
		0: Positive Logic		
		1: Negative Logic		
		Decade: Y2 (same as unit)		
		Hundreds place: Relay 1 output (same as unit)		
		Thousands place: Relay 2 output (same as unit)		
Group F07 Analog and Pulse Output				
F07.00	AO1 output function	00: No output	1	x
F07.01	AO2 output function	01: Output frequency	2	x
F07.02	Y2/HO output function (when used as HO)	02: Command frequency	1	x
		03: Output current (rated current)		
		04: Output voltage(rated voltage)		
		05: Output power		
		06: Bus voltage		
		07: +10V		
		08: keypad potentiometer		
		09: AI1		
		10: AI2		
		11: AI3		
		12: HI (100% to 10.00kHz)		
		13: Output torque (torque absolute value)		
		Group F08 Parameters of Motor 1		
F08.00	Motor 1 type	0: 3-phase async motor 1: Reserved 2:1-phase async motor (Need to remove capacitor of motor) 3: 1-phase async motor(No need to remove capacitor)	0	x
F08.01	Rated power of motor 1	0.10~600.00kW	Model defined	x
F08.02	Rated voltage of motor 1	60~660V	Model defined	x
F08.03	Rated current of motor 1	0.1~1500.0A	Model defined	x
F08.04	Rated frequency of motor 1	20.00~Fmax	Model defined	x
F08.05	Rated speed of motor 1	1~30000	Model defined	x
F08.07	The rated power factor of async motor 1	0.50~0.99	Model defined	x
F08.08	Stator resistance R1 of async motor 1	0.001~65.535Ω	Model defined	x
F08.09	Rotor resistance R2 of async motor 1	0.001~65.535Ω	Model defined	x
F08.10	Leakage inductance L1 of async motor 1	0.001~65.535mH	Model defined	x
F08.11	Mutual inductance L2 of asynchronous motor 1	0.1~6553.5mH	Model defined	x
F08.12	No-load current of async motor 1	0.1~1500.0A	Model defined	x
F08.13	Field weakening coeff 1 of async motor 1	0.0~100.0	87%	x

FR500H Special Purpose Inverters for Multi-pumps Constant Pressure Water Supply

F08.14	Field weakening coeff 2 of async motor 1	0.0~100.0	75%	×
F08.15	Field weakening coeff 3 of async motor 1	0.0~100.0	70%	×
F08.30	Autotuning of motor 1	0: No autotuning	0	×
		1: Static autotuning of motor		
		2: Rotary autotuning of motor		
Group F09 V/f Control Parameters of Motor 1				
F09.00	V/f curve setting	00: Linear V/F	3	×
		01: Multi-stage V/F		
		02: 1.2nd power V/F		
		03: 1.4th power V/F		
		04: 1.6th power V/F		
		05: 1.8th power V/F		
		06: 2.0nd power V/F		
		07: V/F complete separation		
		08: V/F half separation		
		09: 1.2 power inverse curve V/F		
		10: 1.4 power inverse curve V/F		
		11: 1.6 power inverse curve V/F		
		12: 1.8 power inverse curve V/F		
13: 2.0 power inverse curve V/F				
F09.01	Torque boost	0.0%~30.0% 0.0% (fixed torque boost)	0.0%	△
F09.02	Cut-off frequency of torque boost	0.00~Fmax	50.00Hz	△
F09.03	Multi-point V/F frequency 1(F1)	0.00~F09.05	0.00Hz	△
F09.04	Multi-point V/F voltage 1 (V1)	0.0~100.0	0.0%	△
F09.05	Multi-point V/F frequency 2(F2)	F09.03~F09.05	5.00Hz	△
F09.06	Multi-point V/F voltage 2 (V2)	0.0~100.0	14.0%	△
F09.07	Multi-point V/F frequency 3(F3)	F09.05~F09.09	25.00Hz	△
F09.08	Multi-point V/F voltage 3 (V3)	0.0~100.0	50.0%	△
F09.09	Multi-point V/F frequency 4(F4)	F09.07~rated motor frequency	50.00Hz	△
F09.10	Multi-point V/F voltage 4 (V4)	0.0~100.0 Ue=100.0%	100.0%	△
F09.11	V/F slip compensation gain	0.0~300.0%	80.0%	△
F09.12	Stator voltagedrop compensation gain	0.0~200.0%	100.0%	△
F09.13	Excitation boost gain	0.0~200.0%	100.0%	△
F09.14	Oscillation Suppression	0.0~300.0%	100.0%	△
Group F11 Protection Parameters				
F11.00	Current limit control	0: Current limit disabled	2	×
		1: Current limit mode 1		
		2: Current limit mode 2		
F11.01	Current limit	100.0~200.0%	150.0%	×
F11.02	Frequency decreasing time/limit current in constant speed	0.0~6000.0s	5.0s	△

FR500H Special Purpose Inverters for Multi-pumps Constant Pressure Water Supply

	operation)			
F11.03	Current limit mode 2 proportion gain	0.1~100.0%	3.0%	△
F11.04	Current limit mode 2 integral time	0.00~10.00 s (0.00: integral is invalid)	10.00s	△
F11.05	Overvoltage Stall Control	0: Overvoltage stall disabled	2	×
		1: Overvoltage stall mode 1		
		2: Overvoltage stall mode 2		
F11.06	Overvoltage Stall Voltage	600~800V(380V inverter) 320~400V(220V inverter)	730V 370V	×
F11.07	Overvoltage Stall Mode 2 Proportion Gain	0.1~100.0%	50.0%	△
F11.08	Overvoltage Stall Mode 2 frequency limited	0.00~50.00Hz	5.00Hz	△
F11.10	Protection action 1	Unit's place: Bus undervoltage 0: Fault reported and coast to stop 1: Stop according to the stop mode 2: Fault reported but continue to run 3: Fault protection disabled	03330	×
		Ten's place :Power input phase Loss (Err09) (Same as unit's place)		
		Hundred's place :Power output phase loss(Err10) (Same as unit's place)		
		Thousand's place: Motor overload(Err11) (Same as unit's place)		
		Ten thousand's place: Inverter overload(Err12) (Same as unit's place)		
F11.11	Protection action 2	Unit's place: External equipment fault(Err13) 0: Fault reported and coast to stop 1: Stop according to the stop mode 2: Fault reported but continue to run	00000	×
		Ten's digit: EEPROM read/write fault (Err15) (Same as unit's place)		
		Hundred's place: Communication overtime error (Err18) (Same as unit's place)		
		Thousand's place: PID feedback loss (Err19) (Same as unit's place)		
		Ten thousand's place: Continuous running time reached (Err20) (Same as unit's place)		

FR500H Special Purpose Inverters for Multi-pumps Constant Pressure Water Supply

F11.12	Protection action 3	Unit's place: Module temperature detection disconnection (Err24) 0: Fault reported and coast to stop 1: Stop according to the stop mode 2: Fault reported but continue to run	00030	x
		Ten's place: Load becoming 0 (Err25) (Same as unit's place)		
		Hundred's place: reserved		
		thousand's place: reserved		
F11.14	Frequency selection for continuing to run upon fault	0: Current running frequency	1	x
		1: Set frequency		
		2: Frequency upper limit		
		3: Frequency lower limit		
F11.15	Backup frequency upon abnormality	0.00~Fmax	0.00Hz	x
F11.17	Motor overload protection time	30.0~300.0s	60.0s	x
F11.18	Overload alarm	Unit's place: detection option: 0: Always detect 1: Detect at constant speed only	00000	x
		Ten's place: compared object 0: Rated current of motor 1: Rated current of drive		
		Hundred's place: report error or not 0: Do not report 1: Report		
		Thousand's place: Choose whether or not to decelerate 0: No deceleration 1: Do deceleration 2: PID control		
F11.19	Overload alarm threshold	Ten thousand's place: Overload level set mode 0: F11.19 Set 1: VP*F11.19 2: AI1*F11.19 3: AI2*F11.19 4: AI3*F11.19	130.0%	x
		F11.19		
		F11.20		
		F11.21		
F11.22	Overload alarm activated time that exceeding threshold	0.1~60.0s	5.0s	x
F11.21	Inverter overheat warning threshold	50~overheat Temperature	Model defined	x
F11.22	Detection level of power loss	5.0~100.0%	20.0%	x
F11.23	Detection time of power loss	0.1~60.0s	5.0s	x
F11.24	Action selection at instantaneous power	0: Disabled	0	x
		1: Enabled		

FR500H Special Purpose Inverters for Multi-pumps Constant Pressure Water Supply

	failure			
F11.25	Decel time at instantaneous power failure	0.0~6000.0s	5.0s	△
F11.26	Rapid current limit	0: Disabled	0	×
		1: Enabled		
F11.27	Times of automatic reset	0~20	0	×
F11.28	Interval of automatic reset	0.1~100.0s	1.0s	×
F11.29	DO action during fault auto reset	0: Not act	0	×
		1: Act		
F11.30	Instant Power-failure Bus Voltage	60.0%~Recovery Voltage	80%	
F11.31	Instant Power-failure Recovery Voltage	Power Failure Voltage~100.0%	85%	
F11.32	Instant Power-failure Voltage Adjustment Time	0.01~10.00s	0.1	
F11.33	Instant Power-failure Gain K	0.1~100.0%	40.0%	
F11.34	Instant Power-failure Integral Time Ti	0.00~10.00s (0.00: Integral Invalid)	0.1s	
Group F13 Process PID				
F13.00	PID setting	0: F13.01 digital setting	2	×
		1: keypad potentiometer		
		2: AI1		
		3: Communication		
		4: Multi-Reference		
		5: DI7/HI pulse input		
		6: AI2		
7: AI3				
F13.01	PID digital setting	0.0~100.0%	50.0%	△
F13.02	PID feedback	0: AI1	1	×
		1: AI2		
		2: Communication		
		3: AI1+AI2		
		4: AI1-AI2		
		5: Max{AI1, AI2}		
		6: Min{AI1, AI2}		
		7: DI7/HI pulse input		
8: AI3				
F13.03	PID setting feedback range	0~6000.0	100.0	△
F13.04	PID action direction	0: Forward action	0	×
		1: Reverse action		
F13.05	Filtering time of PID setting	0.000~10.000s	0.000s	△
F13.06	Filtering time of PID feedback	0.000~10.000s	0.000s	△
F13.07	Filtering time of PID output	0.000~10.000s	0.000s	△
F13.08	Proportional gain Kp1	0.0~100.0	1.0	△
F13.09	Integration time Ti1	0.01~10.00s	0.10s	△
F13.10	Differential time Td1	0.000~10.000s	0.000s	△
F13.11	Proportional gain Kp2	0.0~100.0	1.0	△

FR500H Special Purpose Inverters for Multi-pumps Constant Pressure Water Supply

F13.12	Integration time Ti2	0.01~10.00s	0.10s	△
F13.13	Differential time Td2	0.000~10.000s	0.000s	△
F13.14	PID setting feedback range	0: No switch, determined by parameters Kp1, Ti1 and Td1	0	×
		1: Auto switch on the basis of input offset		
		2: Switched by terminal		
F13.15	PID parameter switchover deviation 1	0.0~100.0%	20.0%	×
F13.16	PID parameter switchover deviation 2	0.0~100.0%	80.0%	×
F13.17	PID offset limit	0.0~100.0%	0.0%	×
F13.18	PID integral property	Unit's digit (Whether to stop integral operation when the output reaches the limit)	00	×
		0: Continue integral operation		
		1: Stop integral operation		
		Ten's digit (Integral separated)		
		0: Invalid		
1: Valid				
F13.19	PID differential limit	0.0~100.0%	0.5%	×
F13.20	PID initial value	0.0~100.0%	0.0%	×
F13.21	Holding time of PID initial value	0.0~6000.0s	0.0s	×
F13.22	PID output frequency upper limit	PID output frequency lower limit~100.0% (100.0% corresponds to maximum frequency)	100.0%	×
F13.23	PID output frequency lower limit	-100.0% ~ PID output frequency upper limit	0.0%	×
F13.24	Detection value of PID feedback loss	0.0~100.0% 0.0%: Not judging feedback loss	0.0%	×
F13.25	Detection time of PID feedback loss	0.0~30.0s	1.0s	×
F13.26	PID operation at stop	Unit's place: PID operation 0: No PID operation at stop 1: PID operation at stop	000	×
		Ten's place: Output limit 0: Do not limit 1: limit		
		Hundred's place: PID digital given by UP/DOWN 0: Clear to zero when power off 1: Preserve when power off		
F13.27	UP/DOWN speed of PID digital given	0.0~100% (0.0% valid)	0.0%	△
Group F14: Swing Frequency, Fixed Length ,Wakeup and Count				
F14.10	Wakeup frequency	Dormant frequency (F14.12)~Fmax	0.00Hz	△
F14.11	Wakeup delay time	0.0~6000.0s	0.0s	△
F14.12	Dormant frequency	0.00~Wakeup frequency	0.00Hz	△
F14.13	Dormant delay time	0.0~6000.0s	0.0s	△
F14.14	Wakeup Mode Selection	0: frequency wakeup	0	×
		1: pressure wakeup		

FR500H Special Purpose Inverters for Multi-pumps Constant Pressure Water Supply

F14.15	Dormant Mode Selection	0: frequency dormant 1: pressure dormant	0	×
F14.16	Pressure Feedback Source	0: AI1 1: AI2 2: DI7/HI Pulse Input 3: AI3	0	×
F14.17	Wakeup Pressure	0.0%~Dormant Pressure	10.0%	△
F14.18	Dormant Pressure	Wakeup Pressure~100.0%	50.0%	△
Group U00 Status Monitoring				
U00.00	Running frequency	0.00~Fu	0.00Hz	○
U00.01	Set frequency	0.00~Fmax	0.00Hz	○
U00.02	Output voltage	0~660V	0.0V	○
U00.03	Output current	0.0~3000.0A	0.0A	○
U00.04	Output power	-3000.0~3000.0kW	0.0kW	○
U00.05	Estimated Motor Speed	0~60000rpm	0rpm	○
U00.06	Bus voltage	0~1200V	0V	○
U00.07	Synchronous Frequency	0.00~Fu	0.00Hz	○
U00.08	PLC step	1~15	1	○
U00.09	Program Operation Time	0.0~6000.0s(h)	0.0s(h)	○
U00.10	PID set	0~60000	0	○
U00.11	PID feedback	0~60000	0	○
U00.12	Status of DI1~DI5 digital input terminal	DI5 DI4 DI3 DI2 DI1	00000	○
U00.13	Status of DI6~DI7 digital input terminal	DI7 DI6	00	○
U00.14	Status of digital output terminal	R2 R1 Y2 Y1	0000	○
U00.15	AI1 input	0.0~100.0%	0.0%	○
U00.16	AI2 input	0.0~100.0%	0.0%	○
U00.17	AI3 input	-100.0~100.0%	0.0%	○
U00.18	Keypad potentiometer input	0.0~100.0%	0.0%	○
U00.19	HI input	0.00~100.00kHz	0.00kHz	○
U00.20	AO1 output	0.0~100.0%	0.0%	○
U00.21	AO2 output	0.0~100.0%	0.0%	○
U00.22	HO output	0.00~100.00kHz	0.00kHz	○
U00.23	Temperature of inverter	-40.0℃~120.0℃	0.0℃	○
U00.24	Accumulative power-on time	0~65535min	0min	○
U00.25	Accumulative running time	0~6553.5min	0.0min	○
U00.26	Cumulative power-on time	0~65535h	0h	○
U00.27	Cumulative running time	0~65535h	0h	○
U00.28	Count value	0~65535	0	○
U00.29	Length value	0~65535m	0m	○
U00.30	Linear speed	0~65535m/min	0m/Min	
U00.31	Output torque	0.0~300.0%	0.0%	○
U00.32	Motor temperature by PTC	-40℃~200℃	0℃	○
U00.33	Speed detected by encoder	0~60000rpm	0rpm	○

FR500H Special Purpose Inverters for Multi-pumps Constant Pressure Water Supply

U00.34	Encoder lines	0~65535	0	⊙
U00.35	Power dissipation	0~65535kWh	0kWh	⊙
U00.36	VDI1~VDI5 input state	VDI5 VDI4 VDI3 VDI2 VDI1	00000	⊙
U00.37	VDO1~VDO5 output state	VDO5 VDO4 VDO3 VDO2 VDO1	00000	⊙
Group U01 Fault Record				
U01.00	Current Fault Type	Err00 ~ Err45	0	⊙
U01.01	Running frequency when the latest fault occurred	0.00~Fu	0.00Hz	⊙
U01.02	Output current when the latest fault occurred	0.0~3000.0A	0.0A	⊙
U01.03	Bus voltage when the latest fault occurred	0~1200V	0V	⊙
U01.04	Cumulative running time when the latest fault occurred	0~65535h	0h	⊙
U01.05	Code of previous fault	Same as U01.00	0	⊙
U01.06	Running frequency when previous fault occurred	0.00~Fu	0.00Hz	⊙
U01.07	Output current when previous fault occurred	0.0~3000.0A	0.0A	⊙
U01.08	Bus voltage when previous fault occurred	0~1200V	0V	⊙
U01.09	Cumulative running time when previous fault occurred	0~65535h	0h	⊙
U01.10	Before-previous fault code	Same as U01.00	0	⊙
U01.11	Running frequency when before-previous fault occurred	0.00~Fu	0.00Hz	⊙
U01.12	Output current when before-previous fault occurred	0.0~3000.0A	0.0A	⊙
U01.13	Bus voltage when before-previous fault occurred	0~1200V	0V	⊙
U01.14	Cumulative running time when before-previous fault occurred	0~65535h	0h	⊙
H00 group: multi-pumps constant pressure water supply				
H00.00	Special purpose inverter function enable	0: Invalid	0	×
		1: Valid		
H00.01	Work modes selection	0: fixed variable-frequency pumps mode 1: 2 variable-frequency pumps cycle mode 3: MultiFollower 4: MultiMaster	0	×
H00.02	Frequency for add pumps	Frequency for reduce pumps ~ max frequency	50.00Hz	△
H00.03	Frequency for reduce pumps	0.00Hz~frequency for add pumps	5.00Hz	△
H00.04	Pressure tolerance for	0.0~100.0%	0.0%	△

FR500H Special Purpose Inverters for Multi-pumps Constant Pressure Water Supply

add pumps				
H00.05	Pressure tolerance for reduce pumps	0.0~100.0%	0.0%	△
H00.06	Added pumps delay	0.0~300.0s	20.0s	△
H00.07	Reduced pumps delay	0.0~300.0s	15.0s	△
H00.08	Time for added pumps speed arrival max	0.0~300.0s	1.0s	△
H00.09	Time for reduced pumps zero-flow	0.0~300.0s	1.0s	△
H00.10	Switching time	0.1~10.0s	1.0s	×
H00.11	Pumps Status	Unit's place: No.1 pump status 0:Spare 1:Enable	00011	△
		Ten's place: No.2 pump status (same with unit's place)		
		Hundred's place: No.3 pump status (same with unit's place)		
		Thousand's place: No.4 pump status (same with unit's place)		
		Ten thousand's place: No.5 pump status (same with unit's place)		
H00.12	Timing rotate or not	0:fixed order 1:start first stop first 2:timing rotate	0	×
H00.13	Gap of timing rotate	1~60000Min	240Min	×
H00.14	Inverter action selection when adding or reducing pump in single-variable pump mode	0:Inverter stop	0	×
		1:Inverter not stop		
H00.15	Derag Function Enable	0:Disalbe 1:Derag at Start 2:Derag at Stop 3:Derag at Start/Stop 4:Digital Input 5:High Power	0	×
H00.16	+ Derag Speed	0.00~600.00Hz	25.00Hz	△
H00.17	- Derag Speed	0.00~600.00Hz	25.00Hz	△
H00.18	Derag Off Delay	0.0~60.0s	3.0s	△
H00.19	Derag Run Time	0.0~120.0s	10.0s	△
H00.20	Number of Cycles	1~100	5	△
H00.21	High Power Current	0.0~200.0%	120.0%	△
H00.22	High Power Time	0.0~120.0s	10.0s	△
H00.23	Pipe Fill Enable	0:Disalbe 1:Enable	0	×
H00.24	Pipe Fill Rate	0.0~100.0%/s	1.0%/s	△
H00.25	Filled Setpoint	0.0~100.0%	25.0%	△
H00.26	Dry Run Detection Enable	0:Disalbe 1:Enable	0	×
H00.27	Dry Run Detection	0.0~200.0%	30.0%	△

FR500H Special Purpose Inverters for Multi-pumps Constant Pressure Water Supply

Current				
H00.28	Dry Run Detection Time	0.0~120.0s	10.0s	△
H00.29	This inverter can be enabled or not in multi inverter mode	0: Can 1: Can not	1	△
H00.30	The state of this inverter in multi inverter mode	Unit's place: enabled state 0: Not enabled 1: Enabled but not running 2: Enabled and running	00	⊙
		Ten's place: master slave status 0: Slave 1: Can be used as master 2: Currently as master		
H00.31	This inverter can be used as master or not in multi inverter mode	0: Slave 1: Master	1	×
H00.32	Cumulative running time of this inverter in multi inverter mode	0~65000s	0s	△

3.2 H00 group function code detailed explanation

H00.00	Special purpose inverters function enable	0: Invalid	0	×
		1: Valid		

0: Invalid

Standard type

1: Valid

Special purpose type for multi-pumps constant water supply, H00 group parameters valid

H00.01	Work mode selection	0: Fixed variable-frequency pump mode	0	×
		1: 2 variable-frequency pumps cycle mode		
		2:MultiFollower		
		3:MultiMaster		

0: Fixed variable-frequency pump mode

Inverter 3-phase output control a certain pump as fixed variable-frequency pump, other pumps power-frequency run/stop controlled by programmable D0 output. (max control 1*fixed variable-frequency pump+4*power-frequency pumps), power-frequency pump conform to “start first stop first”. Under this mode, 4*power-frequency pumps corresponding to No.2~5 pumps, according to the specific site situation requirements for the numbers of power-frequency pumps, which can be achieved by set multi-functions input (51~54) and H00.11, for more details please refer to H00.11 instructions. Wirings refer to Figure 3-1.

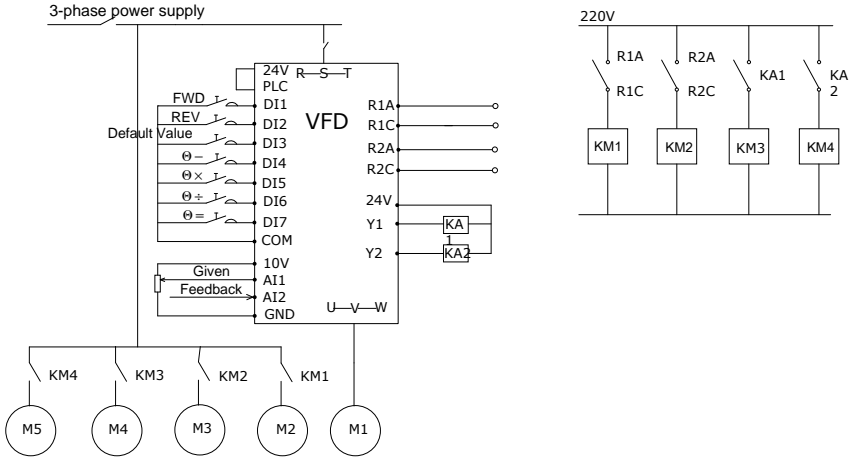

Figure 3-1 Fixed Variable-frequency Pumps Mode Wirings

Fixed variable-frequency pumps mode parameters setting instructions

F01.01=6 (PID preset)	F02.00=1 (external terminals)	F04.02=9(external default input)
F05.00=31 (No.2 power-frequency pump)	F05.01=32 (No.3 power-frequency pump)	F05.02=33(No.4 power-frequency pump)
F05.03=34 (No.5 power-frequency pump)	F13.00=2 (AI1 Pressure Preset)	F13.02=1AI2(Pressure Feedback)
H00.01=0 (single-variable pump, multi-power frequency pump)	H00.11=1111(all pumps start)	

***Note:** in case of using 2 pumps or 3 pumps, set parameter (H00.11 pump status) corresponding to set the un-usage pump to be 0, the pump stops.

1: Two variable-frequency pumps cycle mode

Water supply system doesn't fix a certain pump as variable-frequency pump, when system pressure is insufficient, the running variable-frequency pump firstly switch to grid-power frequency running, and then variable-frequency enable the next new pump, the pump is the new variable-frequency pump. When the system has too much pressure, power-frequency pump stops. The same moment at most only one pump work as variable-frequency pump, another one work on power-frequency, (can control 2*variable-frequency pumps work in cycle). Wirings refer to Figure 3-2.

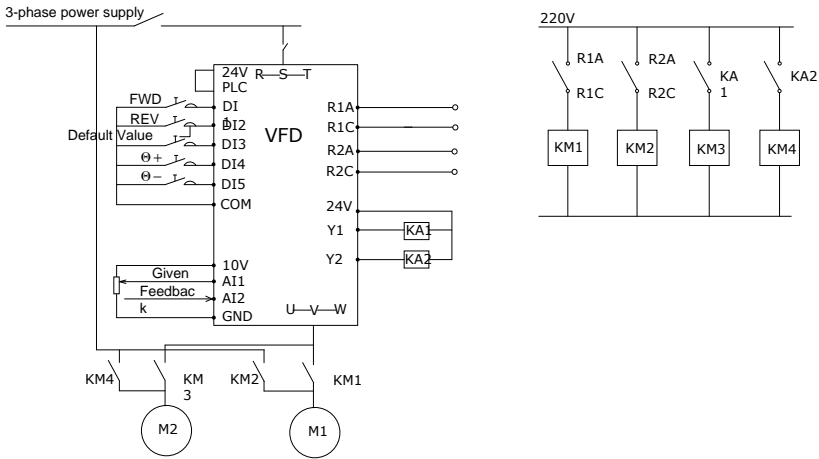

Figure 3-2 2 variable-frequency pumps cycle mode

2 variable-frequency pumps cycle mode parameters setting instructions:

F01.01=6(ID preset)	F02.00=1(External terminals)	F04.02=9(External default input)
F05.00=36(No.2 variable-frequency pump)	F05.01=31(No.2 power-frequency pump)	F05.02=35(No.1 variable-frequency pump)
F05.03=30(No.1 power-frequency pump)	F13.00=2(AI1 pressure preset)	F13.02=1 (AI2 pressure feedback)
H00.01=1(multi-variable pumps)	H00.11=0011(all pumps start)	

*Note: when set parameter (H00.11 pump status) of corresponding unused pump to be zero (spare), the pump stops.

2:MultiFollower Mode

The Multifollower mode controls a system that has the maximum 8 pumps that can change speed. Each pump is controlled by a drive. The internal PID controller of the drive controls all the pumps.

1 of the pumps always controls the system. When the pump in control sees that it is necessary to have more capacity (operates at the maximum frequency), the pump uses the communication bus to make the next pump to start. The next pump increases speed and starts to operate at the speed of the pump in control. Auxiliary pumps operate at the speed of the pump that controls the system.

When the pump that controls the system sees that there is too much capacity (operates at the minimum frequency), it makes the started pump to stop. If no auxiliary pumps operate when the pump in control sees overcapacity, the pump goes to the Sleep mode (if the Sleep function is enabled).

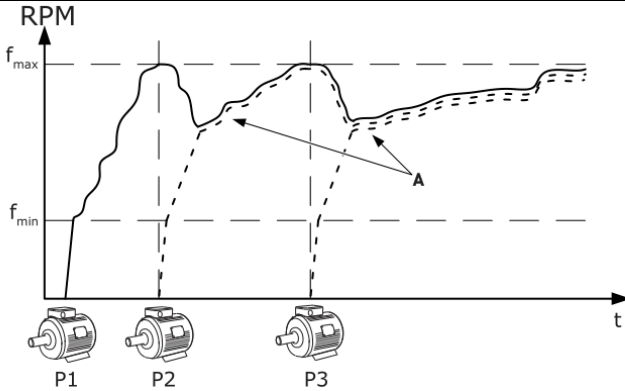

P1: The pump controls the system.

P2: The pump follows the speed of P1

P3: The pump follows the speed of P1

A : Curve A shows the auxiliary pumps that follow the speed of pump 1

Figure.3-3 Control in MultiFollower mode

3:MultiMaster Mode

The Multimaster mode controls a system that has the maximum 8 pumps that can change speed. Each pump is controlled by a drive. The internal PID controller of the drive controls all the pumps.

1 of the pumps always controls the system. When the pump in control sees that it is necessary to have more capacity (operates at the maximum frequency), it locks to a constant production speed and makes the next pump to start and to control the system.

When the pump that controls the system sees that there is too much capacity (operates at the minimum frequency), it stops. The pump that operates at a constant production speed starts to control the system. If there are many pumps that operate at a constant production speed, the started pump starts to control the system. If no pumps operate at a constant production speed when the pump in control sees the overcapacity, the pump goes to the Sleep mode (if the Sleep function is enabled).

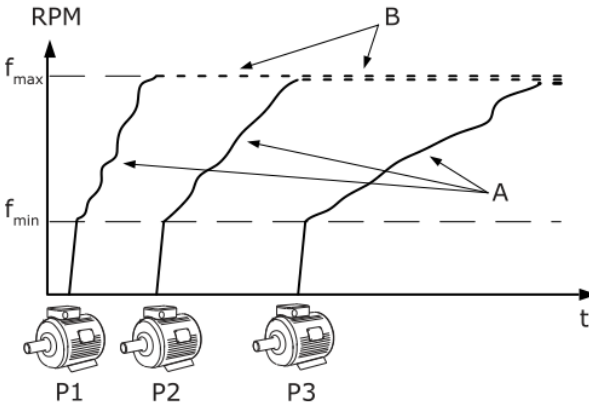

A. Curves A shows the control of the pumps

B. The pumps are locked to the constant production frequency

Fig.3-4 Control in Multimaster mode

FR500H Special Purpose Inverters for Multi-pumps Constant Pressure Water Supply

H00.02	Frequency for add pumps	Frequency for reduce pumps ~max frequency	50.00Hz	△
H00.03	Frequency for reduce pumps	0.00Hz~frequency for add pumps	5.00Hz	△
H00.04	Pressure tolerance for add pumps	0.0~100.0%	0.0%	△
H00.05	Pressure tolerance for reduce pumps	0.0~100.0%	0.0%	△
H00.06	Added pumps delay	0.0~300.0s	20.0s	△
H00.07	Reduced pumps delay	0.0~300.0s	15.0s	△

Add pumps: running frequency≥H00.02 set value, feedback pressure<set pressure-pressure tolerance, and last the delay time set by H00.06, meet the terms of add pumps, add pump.

Reduce pumps: running frequency≤H00.03 set value, feedback pressure>set pressure+pressure tolerance, and last the delay time set by H00.07, meet the terms of reduce pumps, reduce pump.

H00.08	Time for added pumps speed arrival max	0.0~300.0s	1.0s	△
H00.09	Time for reduced pumps zero-flow	0.0~300.0s	1.0s	△

Time for added pumps speed arrival max: when command for adding pumps being sent, a delay(H00.08 parameters) been start, which makes the pump arrive at its rated speed before start another pump(avoid shaking).

Time for reduced pumps zero-flow: when command for adding pumps being sent, a delay(H00.09 parameters) been start, which makes the pump can stop effectively before stop another pump(avoid shaking).

H00.10	Switching time	0.1~10.0s	1.0s	x
--------	----------------	-----------	------	---

This function mainly use for protection inverter and AC power supply from short-circuited, which caused by contactor action delay when a motor switched from variable frequency to power frequency.

Set the shortest time larger than the total of relay action time and contactor action time, generally the contactor action from connect to disconnect takes longer time than switch from disconnect to connect, please operate on longer time.

H00.11	Pump status	Unit's place: No.1 pump status 0:spare 1:start Ten's place: No.2 pump status (same with unit) Hundred's place: No.3 pump status (same with unit) Thousand's place: No.4 pump status (same with unit) Ten thousand's place: No.5 pump status (same with unit)	00011	△
--------	-------------	--	-------	---

Spare: Control terminals DI1~DI7 are multi-functional terminals, which define their functions by setting the value of F04.00~F04.03. Repeat definition is allowed, one of the re-defined terminals valid, the function valid. 51~54 is special functions for constant pressure water supply, instructions as below: 51~54:No.1~No.4 pumps status.

Start: When function of DI1~DI7 terminal defined as 51~54, terminals valid, then the corresponding pumps allowed to run, if terminals invalid, and F04.00~F04.03 corresponding pumps status selected to be 1: start, then the pumps allowed to run, if selected to be 0: spare, then the pumps not allowed to run.

H00.12	Timing rotate or not	0:fixed order 1:start first stop first 2:timing rotate	0	x
--------	----------------------	--	---	---

0: fixed order: start the pumps from small to large.

1: start first stop first: firstly start the running time shortest one when add pumps, firstly stop the running time longest one when reduce pumps.

2: timing rotate

(1) Single variable pump, with assisted pump switched, timing rotate. When 2 pcs or more than 2 pcs assisted pumps running at the same time, if system meets the term of reduce pumps, the firstly started pump will stop first; if the one of them keep running more than H00.13 (timing rotate gap), the assisted pump stops, and start the pump with longest stop time.

(2) Multi variable pump, with assisted pump, with timing rotate. Start current variable pump, when the running frequency higher than frequency for add pumps, start H00.06 delay, if the frequency still higher than frequency for add pumps after the delay, then start the other assisted pump. When variable pump keep running within a certain time, no need to start assisted pumps, if the time ,more than timing rotate time set by H00.12, then stop the current variable pump, switch the assisted pump to variable pump.

H00.13	Gap of timing rotate	1~60000Min	240Min	x
--------	----------------------	------------	--------	---

Single variable mode: when parts of power-frequency motor running, water supply system under stable, to avoid parts of motor keep running in a long time, timing rotate time set for limit the longest running time.

Multi variable mode: when only variable pumps running, and keep running time more than set timing rotate time, then stop the current running pump and switch to another variable pump.

H00.14	Inverter action selection when adding or reducing pump in single-variable pump mode	0: Inverter stop	0	x
		1: Inverter not stop		

0: Inverter stop

In single-variable pump mode, when adding or reducing pump , inverter will stop.

1: inverter not stop

In single-variable pump mode, when adding or reducing pump , inverter will not stop.

H00.15	Derag Function Enable	0: Disalbe 1: Derag at Start 2: Derag at Stop 3: Derag at Start/Stop 4: Digital Input 5: High Power	0	x
H00.16	+ Derag Speed	0.00~600.00Hz	25.00Hz	△
H00.17	- Derag Speed	0.00~600.00Hz	25.00Hz	△
H00.18	Derag Off Delay	0.0~60.0s	3.0s	△
H00.19	Derag Run Time	0.0~120.0s	10.0s	△
H00.20	Number of Cycles	1~100	5	△
H00.21	High Power Current	0.0~200.0%	120.0%	△
H00.22	High Power Time	0.0~120.0s	10.0s	△

Derag Function is used to clear blockage of pump. Below is the diagram of its work mode.

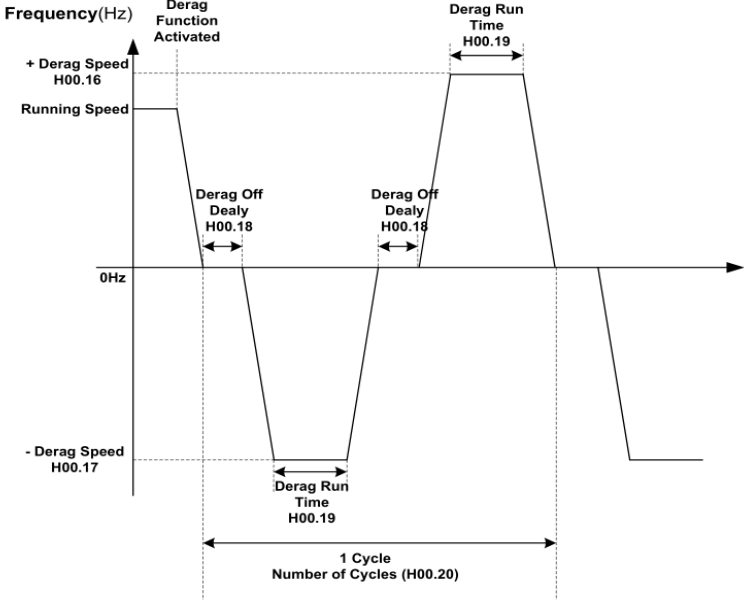

Figure 3-4 Derag Function

H00.23	Pipe Fill Enable	0:Disalbe 1:Enable	0	×
H00.24	Pipe Fill Rate	0.0~100.0%/s	1.0%/s	△
H00.25	Filled Setpoint	0.0~100.0%	25.0%	△

Pipe Fill function. This function is used to make hydraulic pressure stable when beginning

Frequency(Hz)

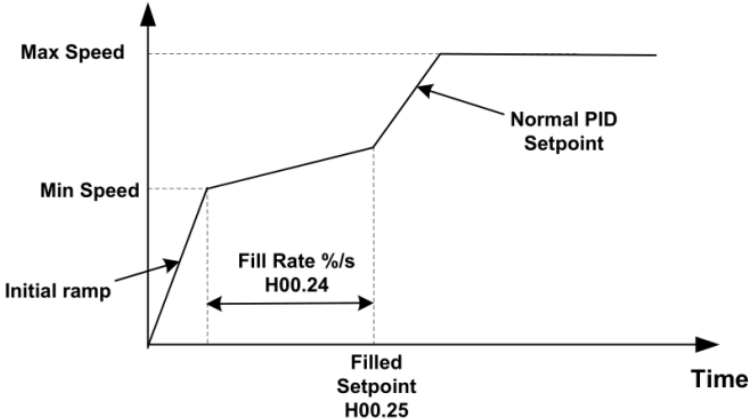

Figure 3-5 Pipe Fill function

FR500H Special Purpose Inverters for Multi-pumps Constant Pressure Water Supply

H00.26	Dry Run Detection Enable	0:Disalbe 1:Enable	0	×
H00.27	Dry Run Detection Current	0.0~200.0%	30.0%	△
H00.28	Dry Run Detection Time	0.0~120.0s	10.0s	△

Dry Run Detection function is used to prevent pump from burning when no water in the tank.

H00.29	This inverter can be enabled or not in multi inverter mode	0: Can 1: Can not	1	△
--------	--	----------------------	---	---

This function code used in multi inverter mode(Multifollower or Multimaster mode) this code determine whether this inverter can be enabled or not by master

H00.30	The state of this inverter in multi inverter mode	Unit's place: enabled state 0: Not enabled 1: Enabled but not running 2: Enabled and running	00	⊙
		Ten's place: master slave status 0: Slave 1: Can be used as master 2: Currently as master		

This function code valid in multi inverter mode. It is used to monitor the current state of this inverter.

Unit's place: enabled state

Indicate whether this inverter has been enabled and what is the current running state

Ten's place: master slave status

Indicate the master slave status of this inverter

H00.31	This inverter can be used as master or not in multi inverter mode	0: Slave 1: Master	1	×
--------	---	-----------------------	---	---

This function code valid in multi inverter mode

0: Slave

This inverter can only be slave mode.

1:Master

This inverter can run as master.

H00.32	Cumulative running time of this inverter in multi inverter mode	0~65000s	0s	△
--------	---	----------	----	---

This is valid in multi inverter mode. Indicate the Cumulative running time of this inverter.

Chapter 4 Maintenance and troubleshooting

FR500H inverter provides a number of warning information and protection, when a fault occurs, the protective function is activated, the inverter will stop output, inverter fault relay contact, and in the inverter displays the fault code on the display panel. Before seeking service user can press the self-examination tips in this section, analyze problems, and identify solutions. If the problem still cannot be excluded, seek services, or contact the dealer you purchase the driver with my company.

Display	Fault Name	Possible Causes	Solutions
Err01	Accel overcurrent	1: The output circuit is grounded or short circuited. 2: The acceleration time is too short. 3: Manual torque boost or V/F curve is not appropriate. 4: The voltage is too low. 5: The startup operation is performed on the rotating motor. 6: A sudden load is added during acceleration. 7: The AC drive model is of too small power class.	1: Eliminate external faults. 2: Increase the acceleration time. 3: Adjust the manual torque boost or V/F curve. 4: Adjust the voltage to normal range. 5: Select rotational speed tracking restart or start the motor after it stops. 6: Remove the added load. 7: Select an AC drive of higher power class
Err02	Decel overcurrent	1: The output circuit is grounded or short circuited. 2: The deceleration time is too short. 3: The voltage is too low. 4: A sudden load is added during deceleration. 5: The braking unit and braking resistor are not installed.	1: Eliminate external faults. 2: Increase the deceleration time. 3: Adjust the voltage to normal range. 4: Remove the added load. 5: Install the braking unit and braking resistor.
Err03	Constant-speed overcurrent	1: The output circuit is grounded or short circuited. 2: The voltage is too low. 3: A sudden load is added during operation. 4: The AC drive model is of too small power class.	1: Eliminate external faults 2: Adjust the voltage to normal range. 3: Remove the added load 4: Select an AC drive of higher power class.
Err04	Accel overvoltage	1: The input voltage is too high. 2: An external force drives the motor during acceleration. 3: The acceleration time is too short. 4: The braking unit and braking resistor are not installed.	1: Adjust the voltage to normal range. 2: Cancel the external force or install a braking resistor. 3: Increase the acceleration time. 4: Install the braking unit and braking resistor.
Err05	Decel overvoltage	1: The input voltage is too high. 2: An external force drives the	1: Adjust the voltage to normal range.

FR500H Special Purpose Inverters for Multi-pumps Constant Pressure Water Supply

		<p>motor during deceleration.</p> <p>3: The deceleration time is too short.</p> <p>4: The braking unit and braking resistor are not installed.</p>	<p>2: Cancel the external force or install the braking resistor.</p> <p>3: Increase the deceleration time.</p> <p>4: Install the braking unit and braking resistor.</p>
Err06	Constant-speed overvoltage	<p>1: The input voltage is too high</p> <p>2: An external force drives the motor during deceleration.</p>	<p>1: Adjust the voltage to normal range.</p> <p>2: Cancel the external force or install the braking resistor.</p>
Err07	Bus undervoltage	<p>1: Instantaneous power failure occurs on the input power supply.</p> <p>2: The AC drive's input voltage is not within the allowable range.</p> <p>3: The bus voltage is abnormal.</p> <p>4: The rectifier bridge and buffer resistor are faulty.</p> <p>5: The drive board is faulty.</p> <p>6: The main control board is faulty.</p>	<p>1: Reset the fault.</p> <p>2: Adjust the voltage to normal range.</p> <p>3: Contact the agent or Frecon.</p>
Err08	Short circuit	<p>1: The output circuit is grounded or short circuited.</p> <p>2: The connecting cable of the motor is too long.</p> <p>3: The module overheats.</p> <p>4: The internal connections become loose.</p> <p>5: The main control board is faulty</p> <p>6: The drive board is faulty.</p> <p>7: The inverter module is faulty.</p>	<p>1: Eliminate external faults.</p> <p>2: Install a reactor or an output filter.</p> <p>3: Check the air filter and the cooling fan.</p> <p>4: Connect all cables properly.</p> <p>5: Contact the agent or Frecon.</p>
Err09	Power input phase loss	<p>1: The three-phase power input is abnormal.</p> <p>2: The drive board is faulty.</p> <p>3: The lightning board is faulty.</p> <p>4: The main control board is faulty.</p>	<p>1: Eliminate external faults.</p> <p>2: Contact the agent or FRECON.</p>
Err10	Power output phase loss	<p>1: The cable connecting the AC drive and the motor is faulty.</p> <p>2: The AC drive's three-phase outputs are unbalanced when the motor is running.</p> <p>3: The drive board is faulty.</p> <p>4: The module is faulty.</p>	<p>1: Eliminate external faults.</p> <p>2: Check whether the motor Three-phase winding is normal.</p> <p>3: Contact the agent or Frecon.</p>
Err11	Motor overload	<p>1: F11-17 is set improperly.</p> <p>2: The load is too heavy or locked-rotor occurs on the motor.</p> <p>3: The AC drive model is of too small power class.</p>	<p>1: Set F11-17 correctly.</p> <p>2: Reduce the load and check the motor and the mechanical condition.</p> <p>3: Select an AC drive of higher power class.</p>
Err12	Inverter overload	<p>1: The load is too heavy or locked-rotor occurs on the motor.</p> <p>2: The AC drive model is of too small power class.</p>	<p>1: Reduce the load and check the motor and mechanical condition.</p> <p>2: Select an AC drive of higher power class.</p>

FR500H Special Purpose Inverters for Multi-pumps Constant Pressure Water Supply

Err13	External equipment fault	1: External fault signal is input via DI.	Reset the operation.
Err14	Module overheat	1: The ambient temperature is too high. 2: The air filter is blocked. 3: The fan is damaged. 4: The thermally sensitive resistor of the module is damaged. 5: The inverter module is damaged.	1: Lower the ambient temperature. 2: Clean the air filter. 3: Replace the damaged fan. 4: Replace the damaged thermally sensitive resistor. 5: Replace the inverter module.
Err15	EEPROM read/write fault	The EEPROM chip is damaged.	Replace the main control board.
Err16	Motor auto-tuning cancelled	Since the identification process, press STOP / RST key	Press STOP / RST key to reset
Err17	Motor auto-tuning fault	1: the motor and the inverter output terminals are not connected 2: The motor does not disengage the load 3: The electrical fault	1: check the connection between the inverter and motor 2: The motor is disengaged load 3: Check the motor
Err18	Communication overtime error	1: The PC is not working properly 2: The communication line is not normal 3: F15 set communication parameters set incorrectly	1: Check the PC Connection 2: Check the communication cable 3: The communication parameters are set correctly
Err19	PID feedback loss	PID feedback set value is less than F13.24	Check the PID feedback signal or set to an appropriate value F13.24
Err20	Continuous running time reached	Set the running time to reach this function	reference F05.14 Description
Err21	Parameter upload fault	1: Is not installed or is not plugged parameter copy card 2: Parameter copy card anomalies 3: The control board abnormalities	1: a copy of the card is properly installed parameters 2: for technical support 3: for technical support
Err22	Parameter download fault	1: Is not installed or is not plugged parameter copy card 2: Parameter copy card anomalies 3: The control board abnormalities	1: A copy of the card is properly installed parameters 2: For technical support 3: For technical support
Err23	Braking unit fault	1: The brake line failure or damage the brake pipe 2: An external braking resistor is too small	1: Check the brake unit, replace the brake pipe 2: Increasing the braking resistor
Err24	Module temperature detection disconnection	The temperature sensor failure or cable break	For technical support
Err25	Load becoming0	The AC drive running current is lower than F11.22	Check that the load is disconnected or the setting F11-22 and F11-23 is correct.
Err26	With-wave current limit fault	1: The load is too heavy or locked rotor occurs on the motor. 2: The AC drive model is of too small power class.	1: Reduce the load and check the motor and mechanical condition. 2: Select an AC drive of higher power class.

FR500H Special Purpose Inverters for Multi-pumps Constant Pressure Water Supply

Err27	Inverter soft-start relay is off	1: The grid voltage is too low 2: Rectifier module failure	1: Check the grid voltage 2: Demand for technical support
Err28	Software version compatibility fault	1: The upper and lower transmission module parameters in the parameter version of the control panel version mismatch.	re-upload module parameters to pass down
Err29	Instantaneous overcurrent	1. Inverter output circuit being grounded or short-circuit; 2. The acceleration and deceleration time is too short; 3. Manually torque boost or V/F curve not appropriate; 4. Voltage too low; 5. Start the running motor; 6. Sudden-load in the acceleration process; 7. Model selection of inverter power is too small.	1. Troubleshooting peripheral problems; 2. To increase the acceleration time; 3. Adjust the manually torque boost or V/F curve; 4. Adjust the voltage to normal range; 5. Select RPM track start or start after motor stopped; 6. Cancel sudden-load; 7. Select the inverter with larger power.
Err30	Instantaneous overvoltage	1: Input voltage is too high; 2. There is external force drag the motor to run in decel process; 3. The deceleration time is too short; 4.No installation of braking resistor.	1: Adjust the voltage to normal range; 2. Cancel external force or install brake resistor; 3. To increase the deceleration time; 4.Install braking resistor
Err40	Set running time finished	1. Cumulative running time (U00.27) no less than using time (F00.25)	1. Contact distributors
Err45	Dry run error	1. Water shortage	1. set appropriate detection level of dry run